

Specific Support Action

NanoRoad SME

Technology Roadmapping for SMEs

Potential Applications of Nanomaterials by SMEs in Future Products

NanoEquity Europe 2006, 11. Juli 2006

Steinbeis-Europa-Zentrum, Dr. Jonathan Loeffler

Which nanomaterials for products in 2010-2015?

Difficulty to evaluate the future technological developments

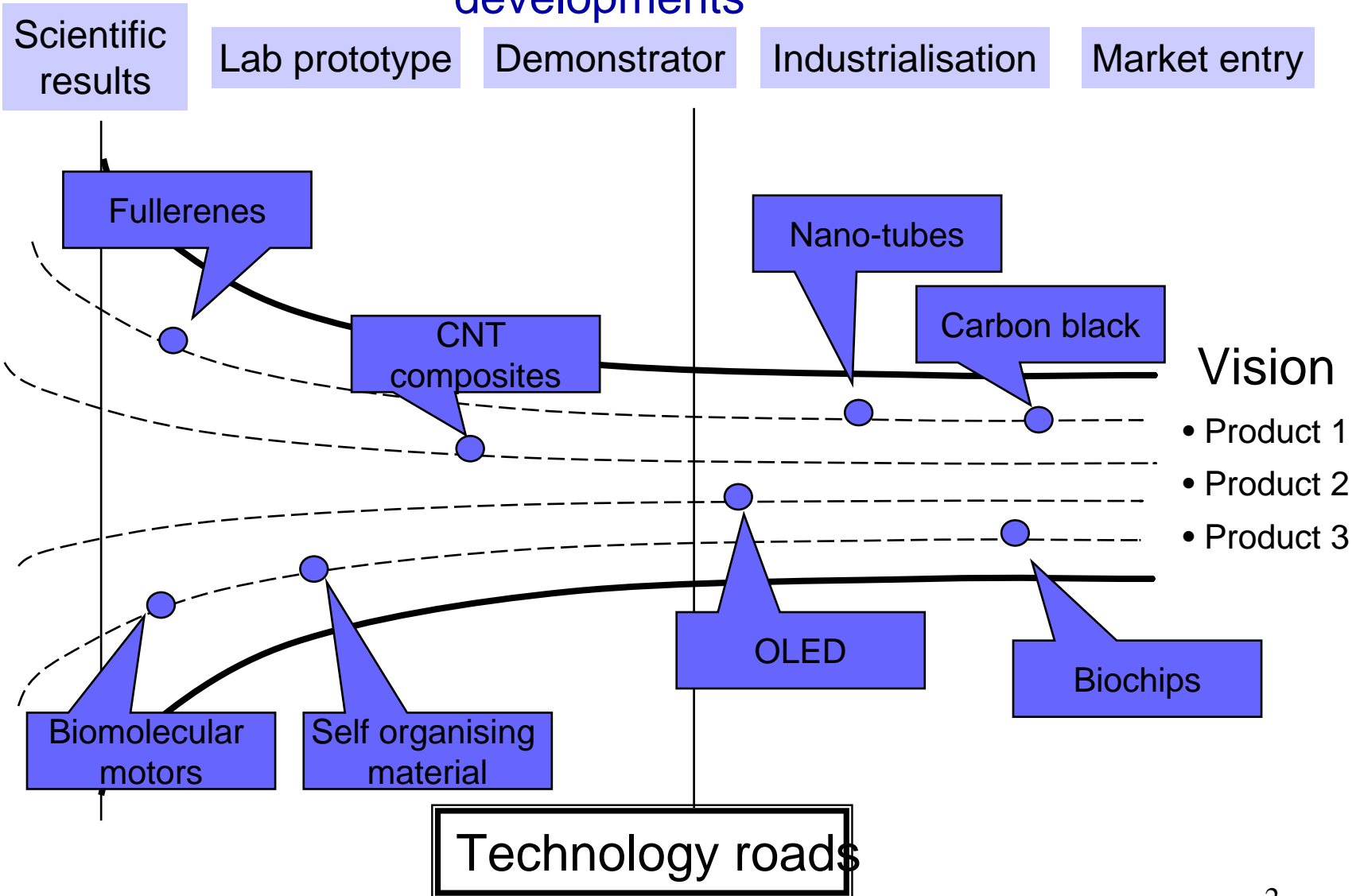



Overview of relevant nanomaterials

1. Carbon-based nanomaterials

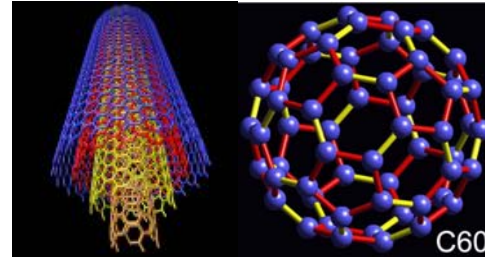

2. Nano-composites

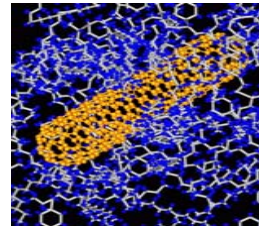

3. Nano Metals & Alloys

4. Biological Nanomaterials

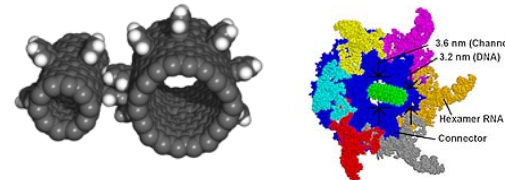

5. Nano-Polymers

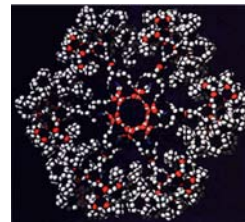

6. Nano-Glasses



7. Nano-ceramics

Potential applications in 4 industrial sectors

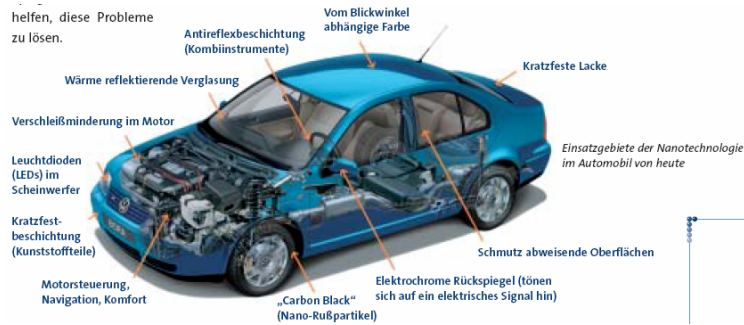

Automotive industry

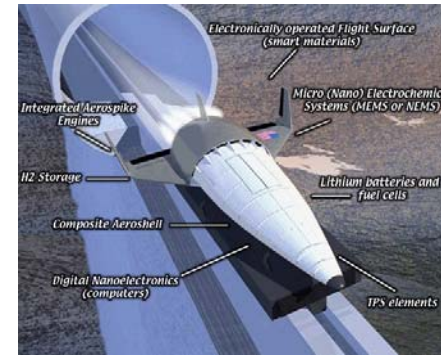

Aeronautics



Medical & Health



Energy



❖ Industrial SWOT analysis

- Which nanomaterials are already used in this sector? Why? What are the advantages? (Strengths)
- What are the needs and the barriers in this sector? (Weaknesses)
- Which nanomaterials could help to overcome these barriers? (Opportunities)
- What are the risks? (Threats)

SWOT analysis – Automotive industry

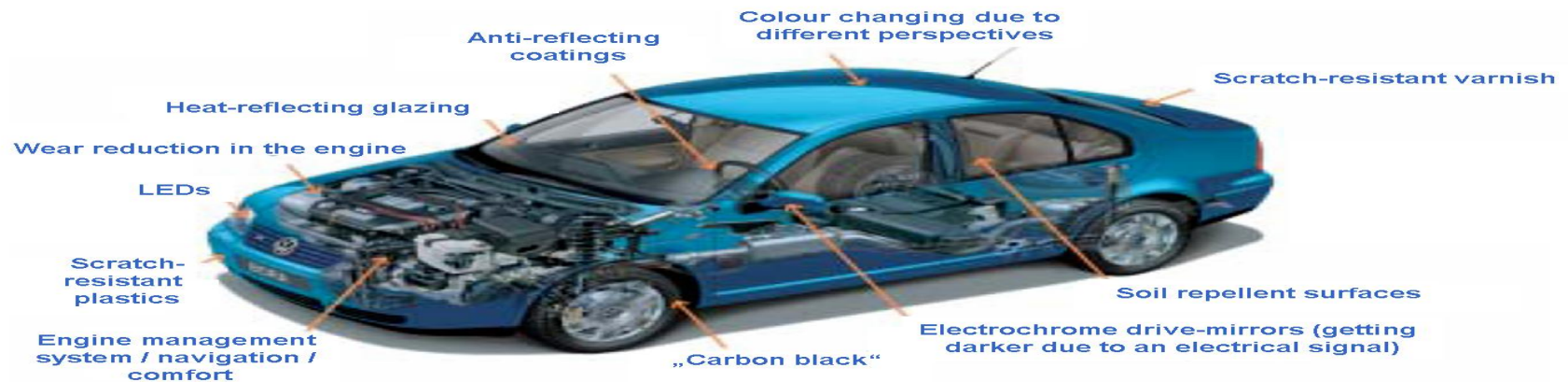
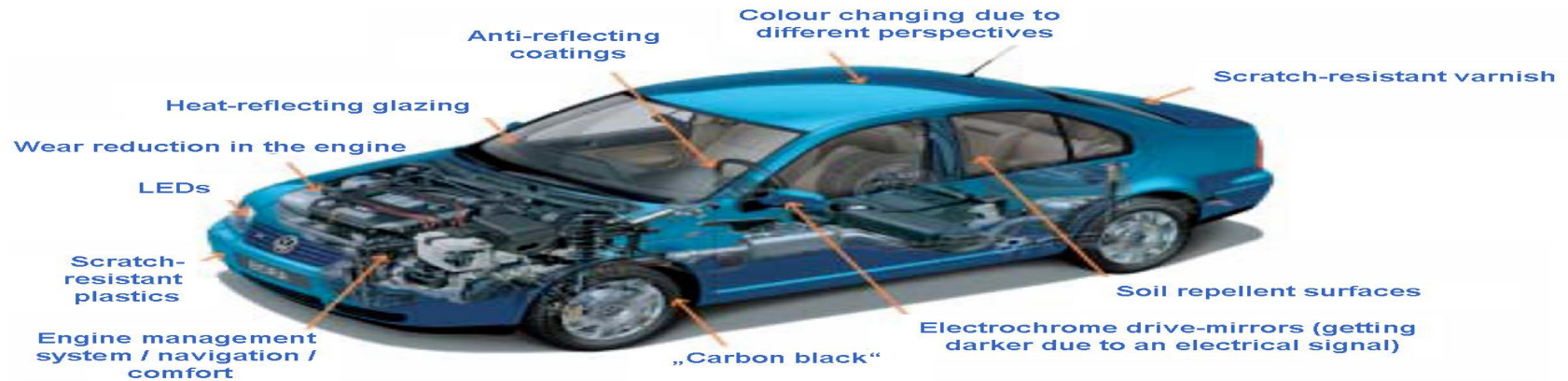

SWOT Aeronautics sector

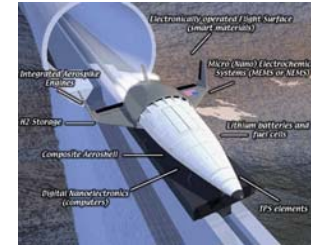

APPLICATIONS

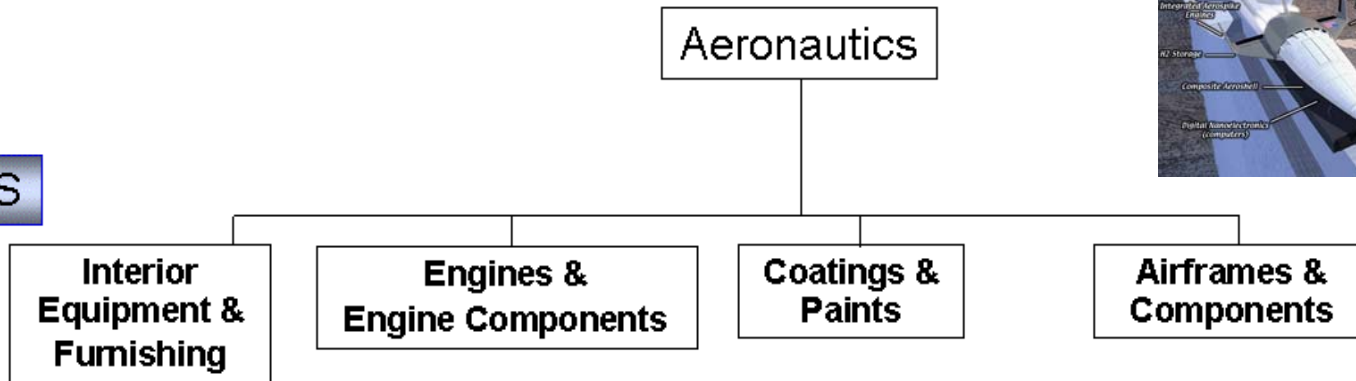

PRODUCTS

- Cabinets
- Doors
- Seats
- Toilets
- Noise Reduction

- Anti-Vibration Equipment
- Blades
- Ignition Components
- Combustion Components

- Lacquers
- Powder coatings
- Rain Protection Systems

- Hydraulic / Pneumatic Equipment & Components
- Landing Gear / Wheels / Brake
- Windows
- Inflatables

Nano-materials

Polymer matrix Nanocomposites

Metal matrix Nanocomposites

Nanotubes / Nanofibrils / Nanocapsules

- Nanopowders
- CFKP reinforced composites



Application areas of nanomaterials

Carbon based

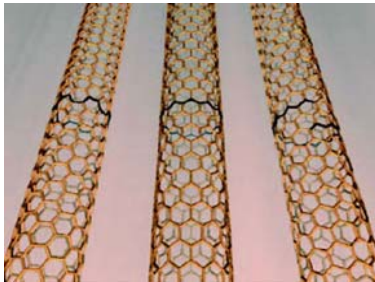

Nanotubes

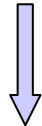

The Samsung 4.5" full-color nanotube display.

Nano-composites

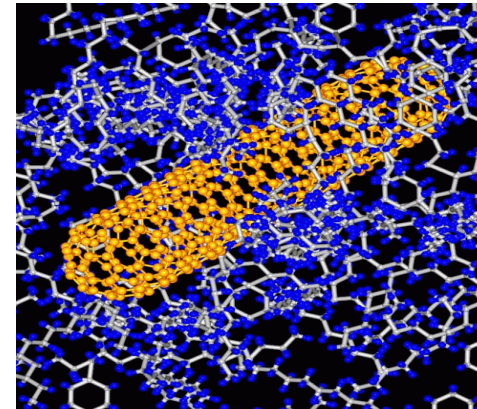

Polymer-nanotubes composites

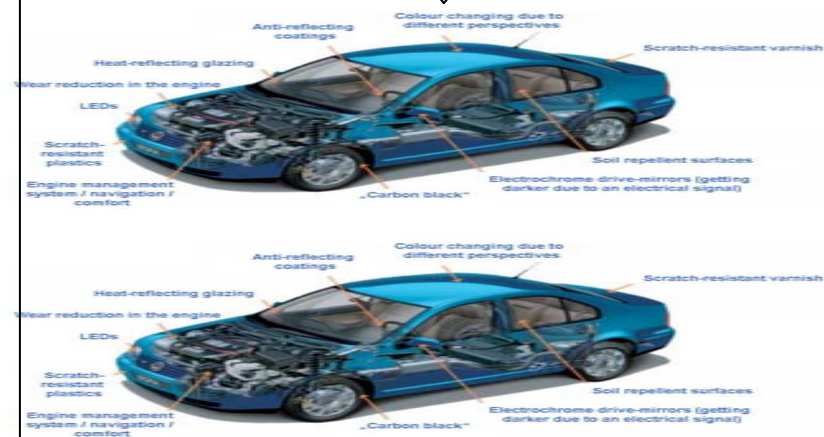

Building the bridge with Technology Roadmapping !

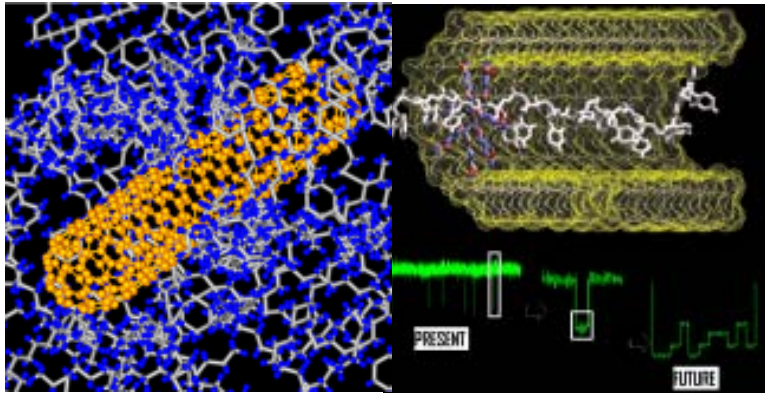

Future performances

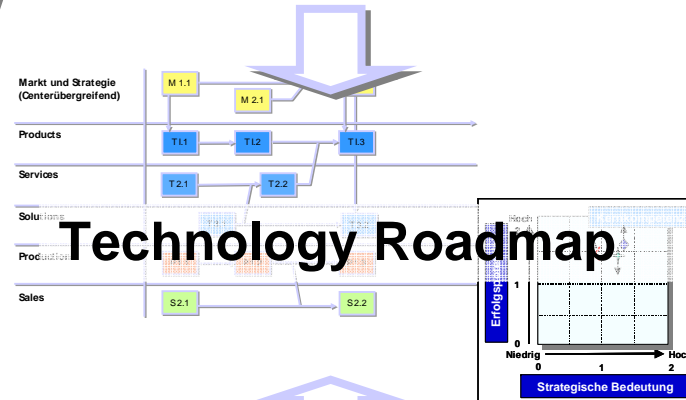

Actual key competences

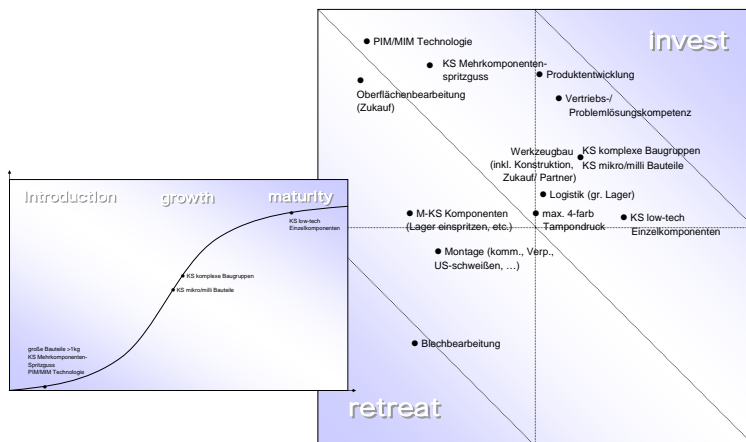



Types of roadmaps

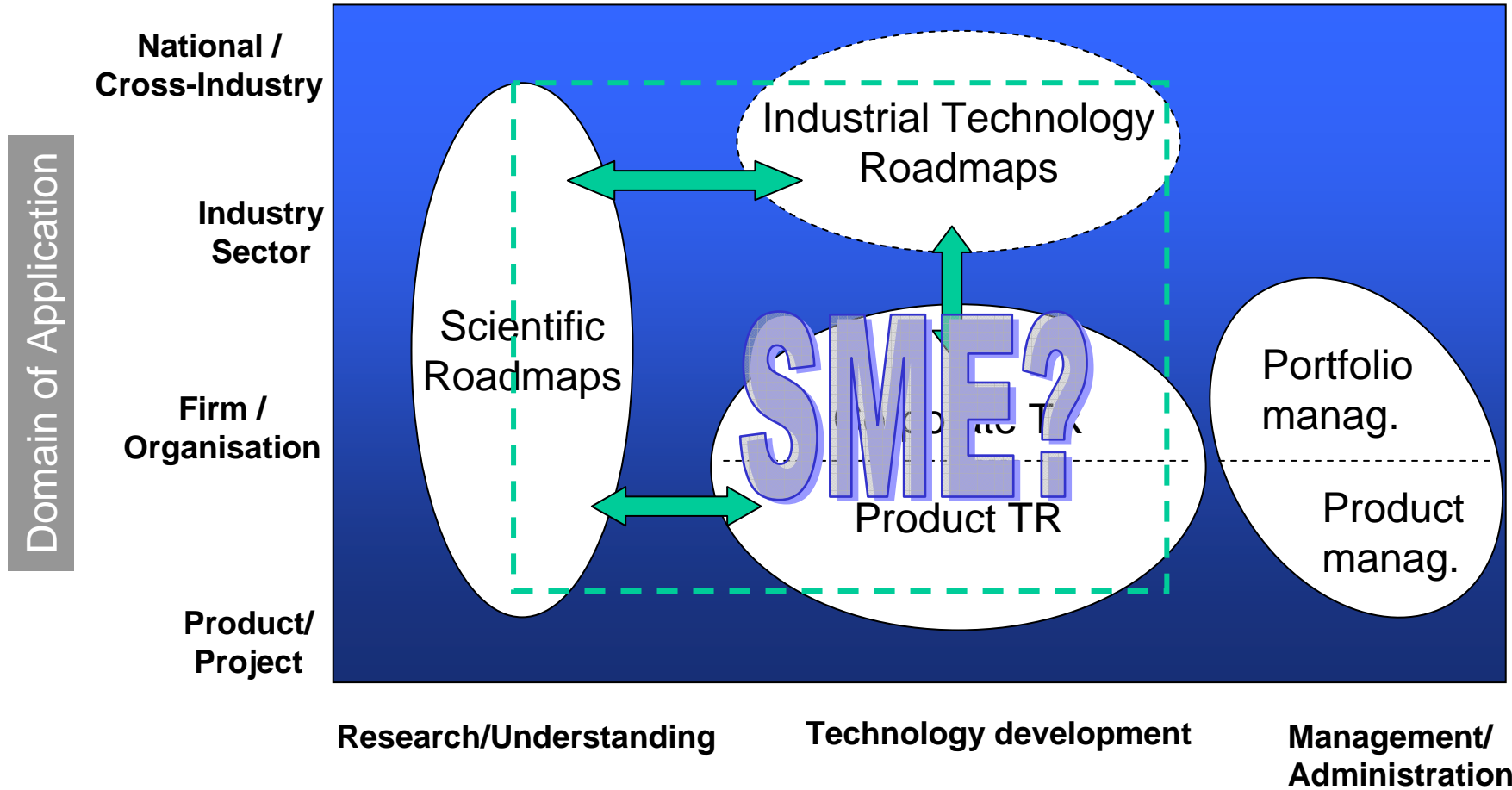

Objective

(Source: R. Albright & R. Schaller „Technology Roadmap Workshop“Office of Naval Research, Washington, October 30, 1998)



TRM for SMEs

Answers to simple questions important for SMEs

❖ SME survey

- What are the success factors of companies already working with nanomaterials ?
- What are the main barriers for the industrial use of nanomaterials by SMEs?
- What are the strategic information necessary for SMEs to evaluate the future industrial development of nanomaterials?



Overview about the participants

- ❖ 337 companies from 11 countries
- ❖ 75% have less than 250 employees and are considered as SME
- ❖ 163 enterprises are presently working with nanomaterials (120 SMEs) – 55% users, 43% producers, 58% designers
- ❖ 80 companies are planning to work with nanomaterials within the next 2 years (61 SMEs) – 80% to be users, 10% to be producers, 19% designers/developers
- ❖ 94 enterprises has no experience and are not planning to work with nanomaterials in the next 2 years



Sector specific distribution

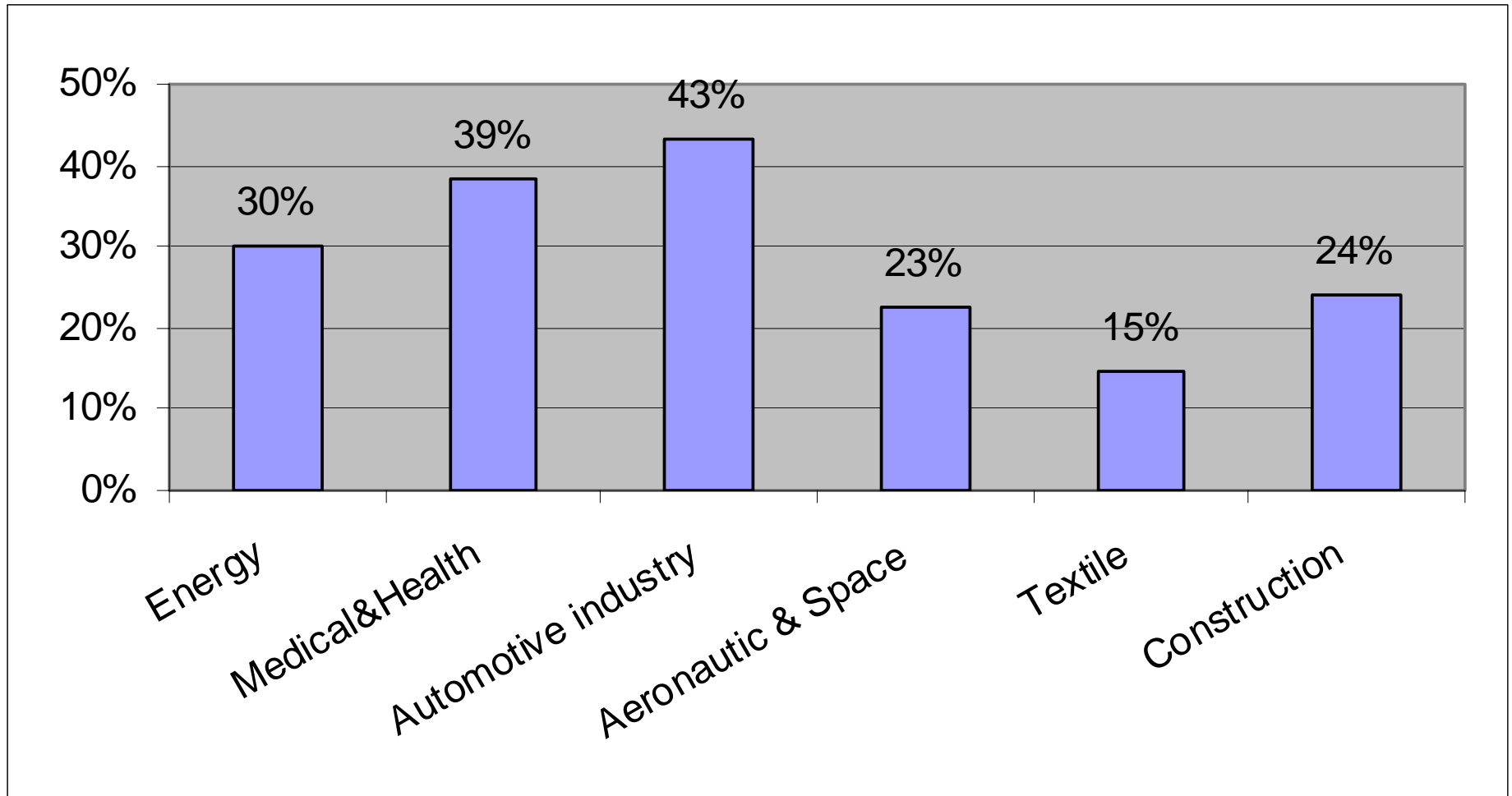



Success factors

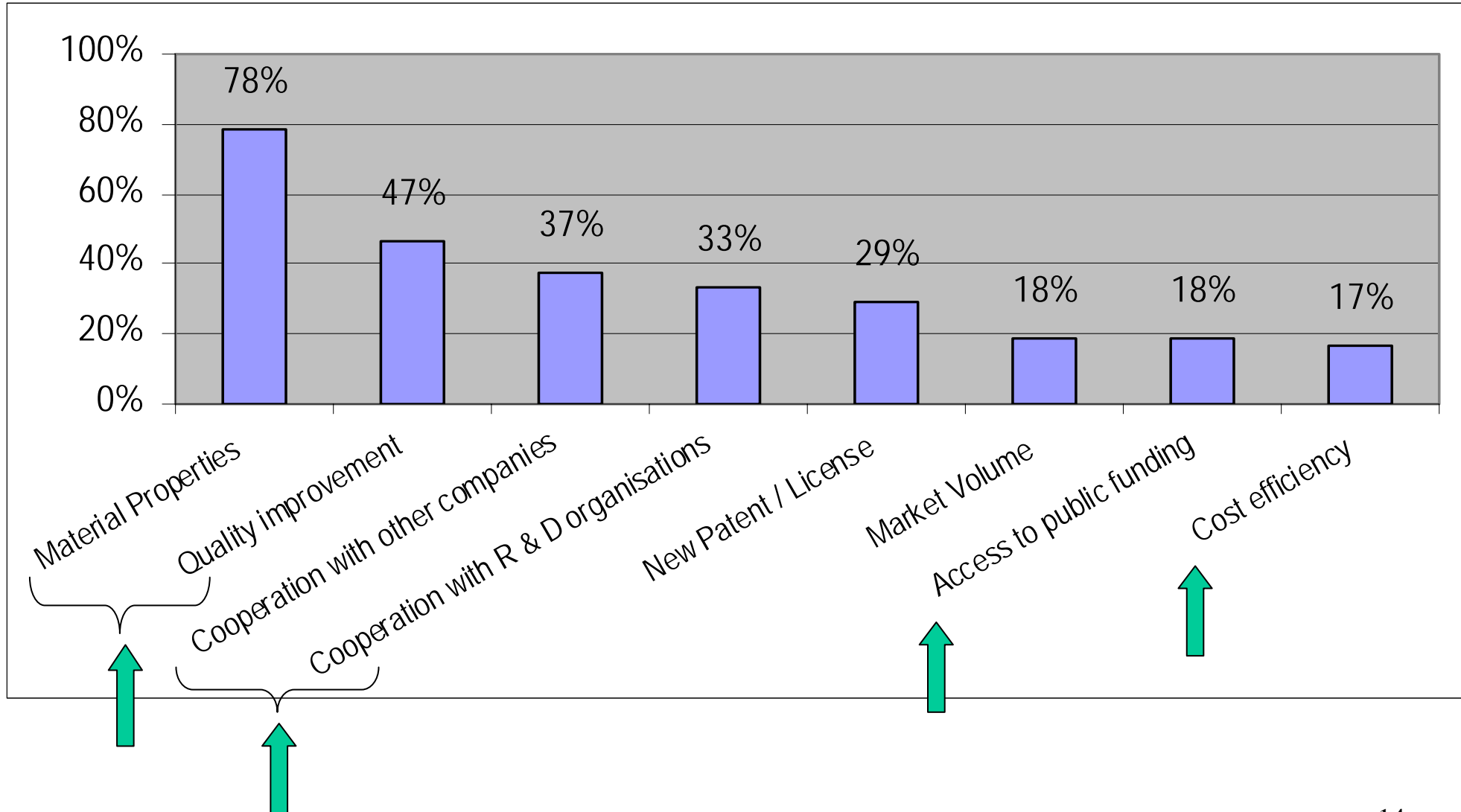



Barriers for SMEs

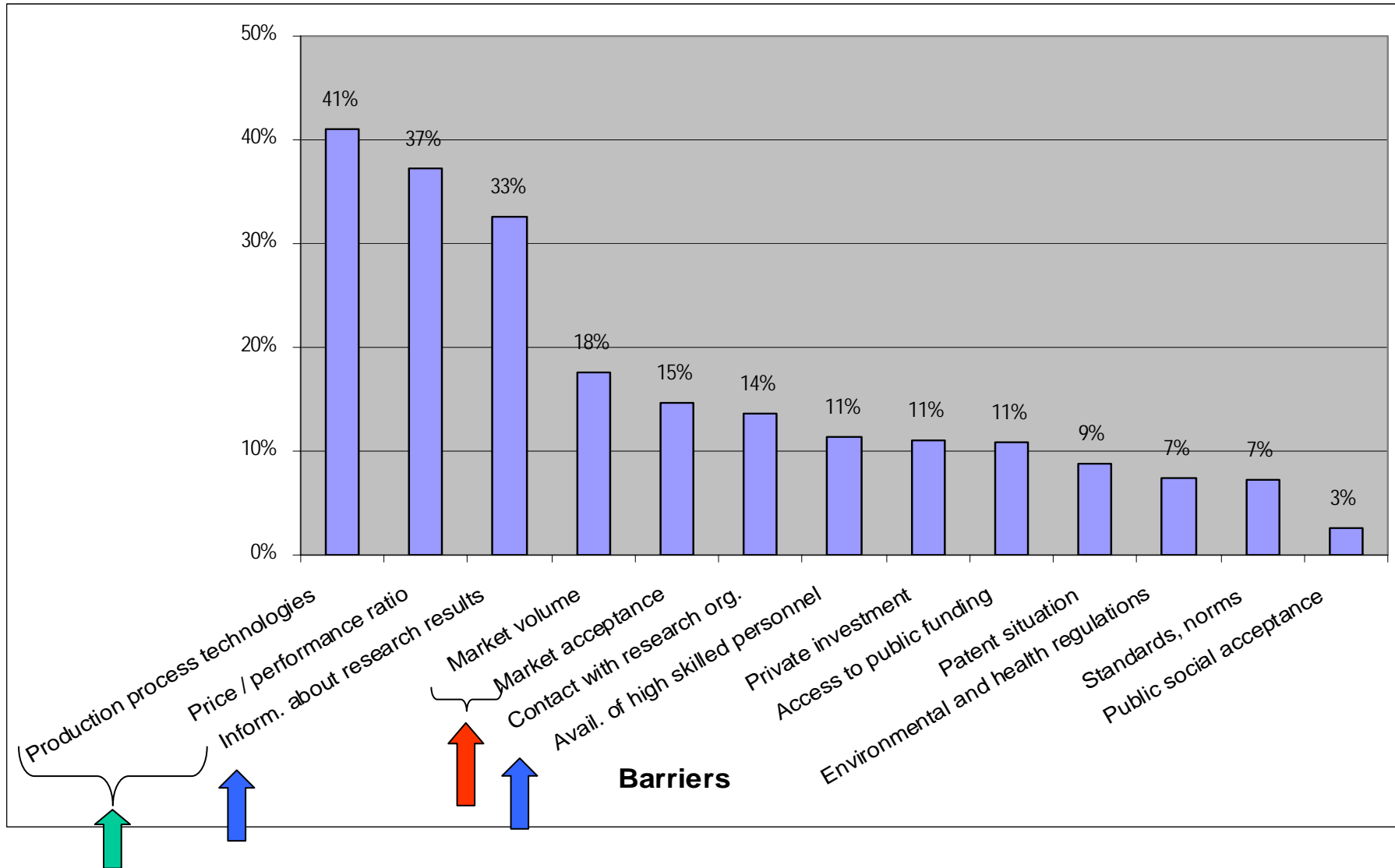



Most important strategic criteria

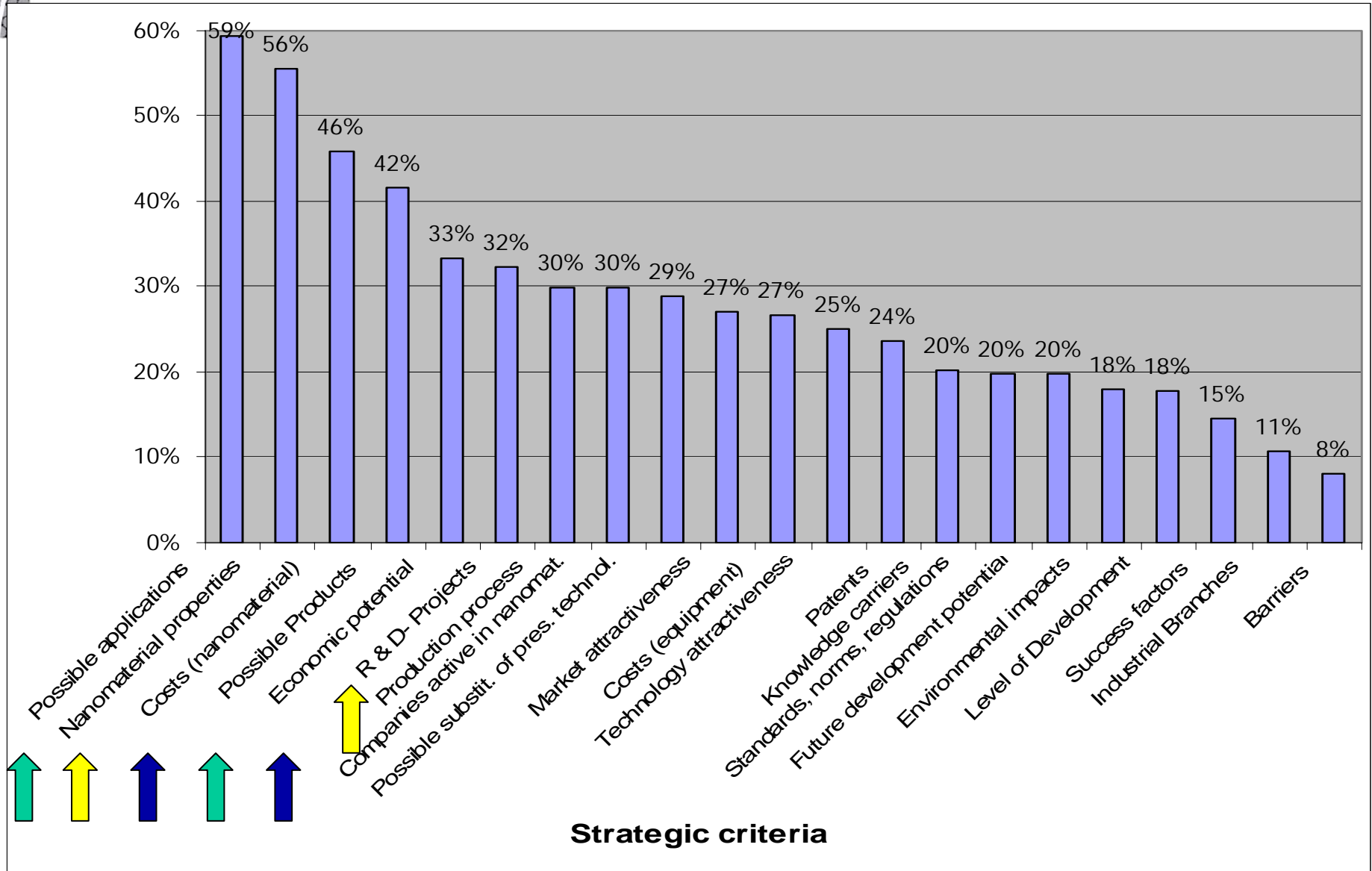

Conclusions of the SME survey

- ❖ **Success factors of companies using nanomaterials**
 - Material properties (78%) / Quality improvement (47%)
 - Cooperation with other companies (37%) / R&D organisations (33%)

- ❖ **Barriers for the use of nanomaterials by SMEs**
 - Production processes (41%) - price/performance ratio (37%)
 - Information about research results (33%)

- ❖ **Strategic criteria for roadmaps applied to SMEs**
 - Possible applications / possible products (58%)
 - Nanomaterials properties (57%)
 - Costs of nanomaterials (49%)



Technology driven approach

Market driven approach

R&D surveys

SWOT

Industry survey

- Carbon
- Ceramics
- Polymers
- Composites
- Metals & alloys
- Glass
- Biological materials

- Energy
- Med. & Health
- Auto.
- Aero.
- SMEs
- Big co.

Relevant nanomaterials

Application areas

Improved properties

Level of dev.

Products

Needs

Barriers

Success factors

DATABASE

Roadmapping

Roadmapping: search possibilities



1. Material properties
2. Applications



**1. Selected roadmaps:
tailored filters**

 **SEARCH**

Search profiles v

**“AND”
search
between
criteria**

**Keywords
→ all text
input**

Search parameters

Select categories Match all selected categories

Select properties Match all selected properties

Select domains of applications Match all selected domains of applications

Level of development

All

Scientific result / technology invention

Laboratory prototype

Industrial demonstrator

Industrialisation

Market entry

Key words : Match all key words

Material properties
When a sub-category will automatically select the main corresponding category

<input type="checkbox"/> Chemical	<input type="checkbox"/> Optical
<input type="checkbox"/> Biocompatibility	<input type="checkbox"/> Absorption
<input type="checkbox"/> Catalytic behaviour	<input type="checkbox"/> Change of colour
<input type="checkbox"/> Corrosion behaviour	<input type="checkbox"/> Emission
<input type="checkbox"/> Inertness (for compacted material)	<input type="checkbox"/> Luminescence
<input type="checkbox"/> Inflammability	<input type="checkbox"/> Opalescence
<input type="checkbox"/> Reactivity (for dispersed material)	<input type="checkbox"/> Photochromie
<input type="checkbox"/> Toxicity	<input type="checkbox"/> Reflectance
<input type="checkbox"/> Other	<input type="checkbox"/> Transmission
<input type="checkbox"/> Diffusion	<input type="checkbox"/> Transparency
<input type="checkbox"/> Gas diffusion through pores / Free volume diffusion	<input type="checkbox"/> Other
<input type="checkbox"/> Thermal diffusion coefficient	<input type="checkbox"/> Properties of fluids
<input type="checkbox"/> Other	<input type="checkbox"/> Interfacial tension
<input type="checkbox"/> Electrical	<input type="checkbox"/> Surface tension
<input type="checkbox"/> Conductivity / Resistance / Band gap	<input type="checkbox"/> Tixotropie
	<input type="checkbox"/> Viscosity
	<input type="checkbox"/> Other

Choose criteria (“OR” search)

Branch roadmaps

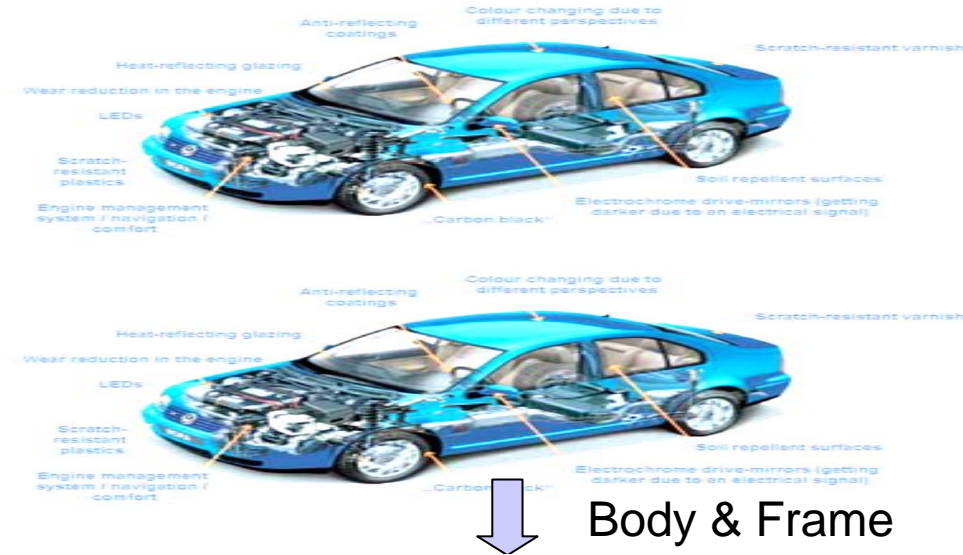

LEVEL OF DEVELOPMENT

Legend : Technology Invention (Red), Laboratory Prototype (Orange), Industrial Demonstrator (Yellow), Industrialisation (Green), Market Entry (Blue)

	2006	2007	2008	2009	2010	2011	2012	2013	2014	2015	2016	2017	2018	2019	2020
Aluminium (Al), Magnesium (Mg) and Al-Mg alloys - Bulk ...		ID		I						ME					
Carbon Nanofoam		TI			LP			ID		I				ME	
Carbon Nanotubes								ME							
Metal Matrix Composites (MMC)			I							ME					
Montmorillonite nanoclays (platelet)		I							ME						
Nickel (carbon coated) [Ni-C] powders								ME							
Polymer with carbon nanoparticles/fillers (bulk)			ID				I							ME	
Polyolefin with clays (bulk)			I							ME					
Rubber-clay nanocomposite (bulk)			I							ME					
Stainless Steel - Bulk material with nano-grains	I								ME						
Steel with nanocrystalline surface	I								ME						
Titanium (Ti) - Bulk material with nano-grains		ID		I						ME					
Titanium-Aluminium (Ti-Al) alloys - Bulk materials with ...		ID				I					ME				



Relevant product development steps depending from the SME type

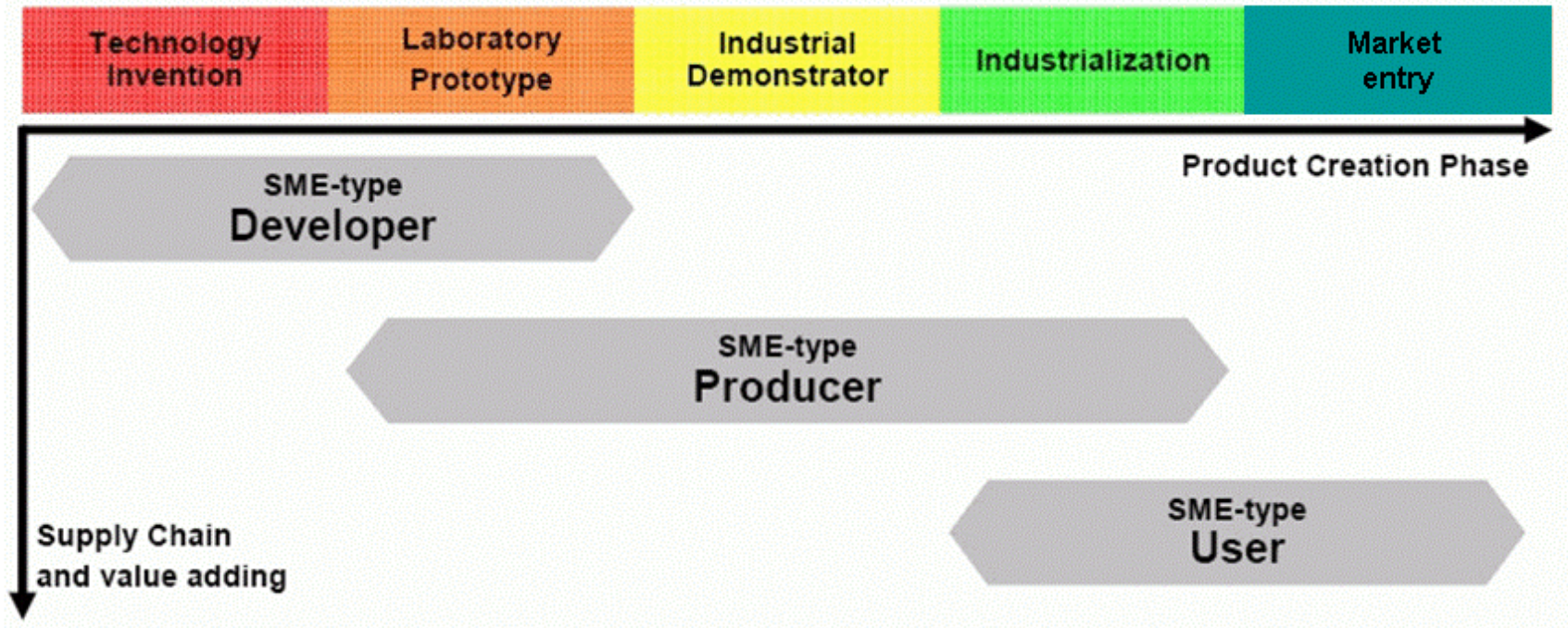

Nanomaterial Info Sheet: Example (1)



Carbon Nanotubes

Carbon nanotubes are tubes consisting of a rolled up mesh like configuration of carbon atoms.



Short material
description

Description of material properties which have been improved :

Hardness

Nanotubes shows a strength up to 45 billion pascals [Collins 2000] and a high resilience.

Density

Nanotubes have a low density of 1,3 to 1,4 g/cm³ [Collins 2000].



Improvements and material properties

Other mechanical properties

Nanotubes have an extraordinary high aspect ratio. The tubes have diameters of 1-2 nm and lengths of up to several micrometers.

Advantages :

- their hardness in combination with their resilience they could enhance the strength of compound materials.

Disadvantages :

- The main obstacle for a broader use of CNT is the extremely high cost. It is about 150 Euro per gram for SWCNT. [Luther 2004]
- It is difficult to produce pure Nanotubes of a specific constitution (length, metal-like, semiconducting, isolating, SWNT, MWNT), or to separate them from each other. [Krupke 2004, Haddon 2004]
- There is an ongoing need for a more thorough understanding of growth mechanisms for a selective and uniform production of carbon nanotubes with specific dimensions and physical properties.
- The toxicity in combination with their chemical inertness could be a problem [Lam 2004]
- Their strong fibrous nature may result in similar health risk to asbestos fibres. If elements such as iron from catalysts in the production process are present there is the possibility that the nanotubes may have free-radical releasing, pro-inflammatory properties. [Royal Academy 2004].
- The extraordinary properties belong to the single nanotubes. Not solved until now is the question how to transform these properties like thermal conductivity, or strength to bulk material.



Specific industrial applications in this domain
+ time scale + description

Possible applications:

Formation of foams with carbon nanotubes

Time Scale : Long term (6-10 years)

Description :

The formation of foams with carbon nanotubes in polymer composite materials for use in a range of polymer foam materials is being investigated. Such foams are expected to have improved mechanical, electrical and thermal properties. Expected applications are as lightweight components (typ. densities of carbon nanofoams are in the range of 0.25 to 1.00 g/cm³) in automotive systems and in packaging materials, leading to lower transport costs.

Case studies in SMEs



Aim: Demonstrate the validity of the nano-technology roadmap in the development of the product strategy of a company

results: company specific technology roadmaps

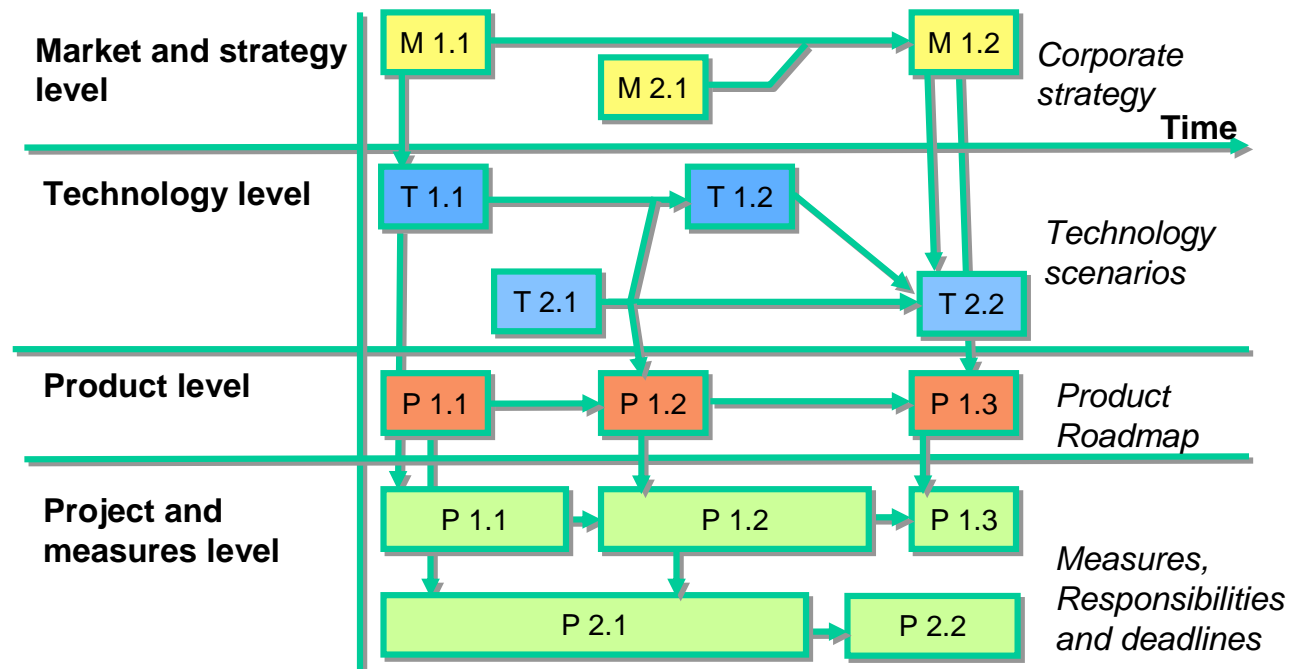



- ❖ Long fibre reinforced thermoplastics (LFT)
- ❖ Customers are injection moulding firms that work with thermoplastic elastomer.
- ❖ Suitable materials are tailored to the meet customer specific requirements
- ❖ Small, innovative company with little under 50 employees
- ❖ Spin-off, founded 1998
- ❖ The company is planning to work with nanomaterials within the next 2 years e.g. flame retardant.
- ❖ The role of the company in the nanomaterial value chain will be user, maybe also a producer in the long term



Company's feedback

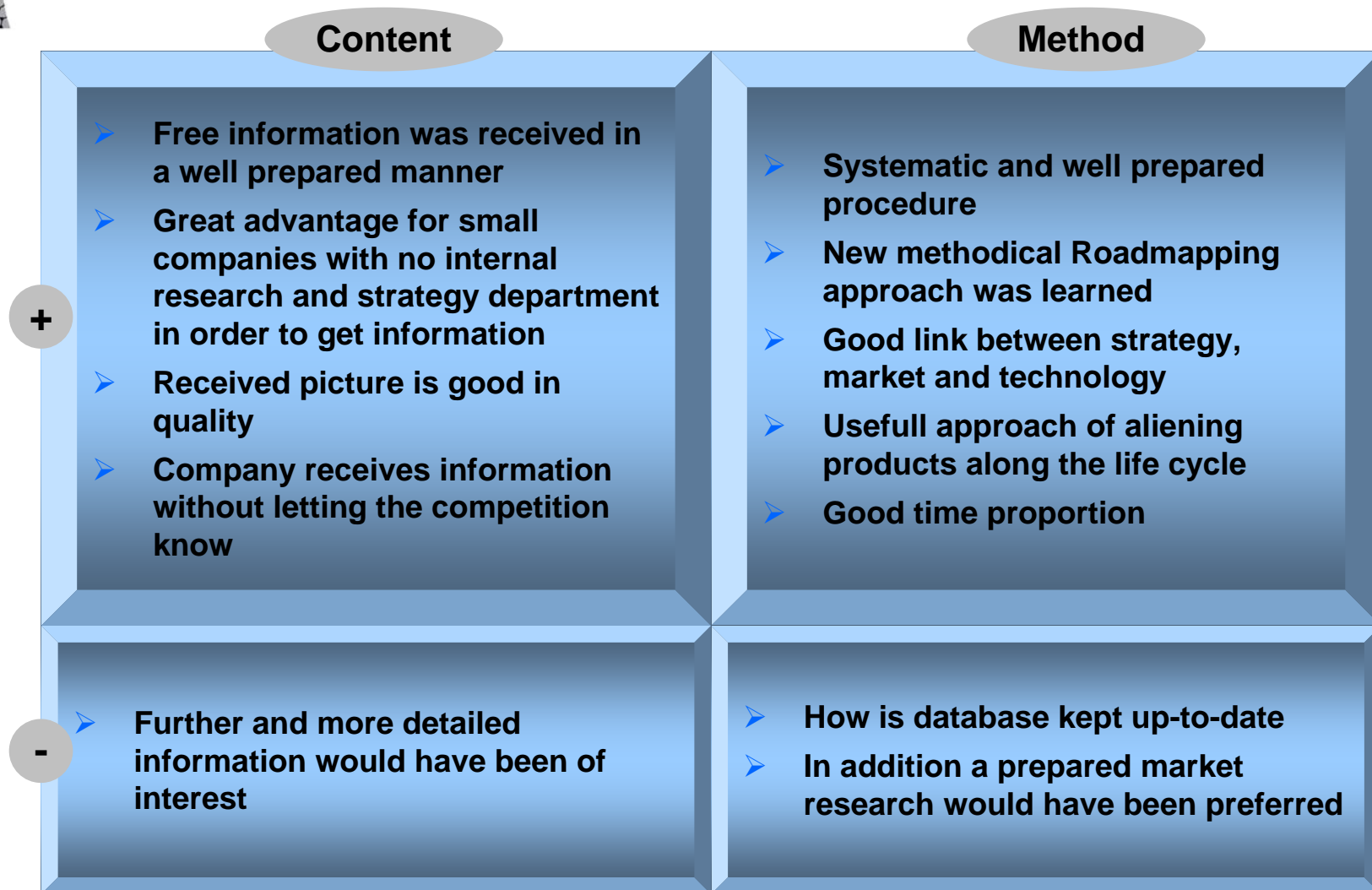



Home
Scientific progress in Nanomaterials
Industrial Applications
SME-Survey
What's new?
Downloads
Partners
Contact

Project NanoRoadSME

Nanomaterial Roadmap 2015

Industrial Adaption to Small and Medium Sized Enterprises

Trends in Research and Development

Product and Application Visions

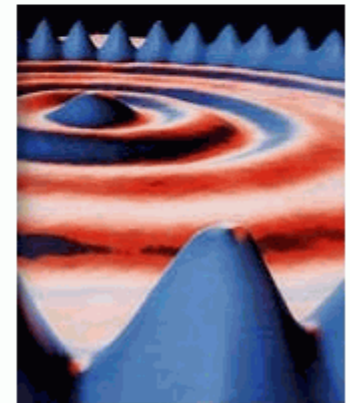

FFG

ÖSTERREICHISCHE
FORSCHUNGSFÖRDERUNGSGESELLSCHAFT
AUSTRIAN RESEARCH PROMOTION AGENCY

UPM – Biomaterial laboratory of the
Universidad Politecnica de Madrid (Spain)



Thank you



Fraunhofer Institut
Keramische Technologien
und Sinterwerkstoffe



Fraunhofer Institut
Produktionstechnik und
Automatisierung

Malsch
Techno
Valuation

